



CYCLOPS-7
Submersible Sensors

User's Manual



Version 1.8
April 14, 2010
P/N 998-2100

TURNER DESIGNS
845 W. Maude Ave.
Sunnyvale, CA 94085
Phone: (408) 749-0994
FAX: (408) 749-0998

Table of Contents

1.0 INTRODUCTION	4
1.1 DESCRIPTION	4
1.2 INSPECTION AND SETUP.....	4
<i>Optional Accessories include:</i>	4
1.3 FUNCTIONAL TEST	5
2.0 MEASUREMENTS WITH THE CYCLOPS-7	6
INTRODUCTION.....	6
2.1 SETTING THE GAIN	6
2.1.1 <i>Gain Determination Procedure</i>	6
2.1.2 <i>Static Gain Control</i>	6
2.1.3 <i>Auto Gaining</i>	7
2.2 CALIBRATION USING STANDARD(S) WITH KNOWN CONCENTRATIONS	7
2.3 RECOMMENDED LAB PRACTICES FOR CYCLOPS-7 MEASUREMENTS.....	7
2.4 USING THE (SSS) SOLID SECONDARY STANDARD, (OPTIONAL ACCESSORY)	8
2.4.1 <i>Installing the Solid Secondary Standard</i>	9
2.4.2 <i>Using the Solid Secondary Standard for In Vivo Chlorophyll Application</i>	10
2.4.3 <i>Using the Solid Secondary Standard for Dye Tracing Application</i>	10
3.0 TURBIDITY CYCLOPS-7	11
INTRODUCTION.....	11
3.1 CALIBRATION	11
4.0 RECOMMENDED MEASUREMENT PRACTICES	12
4.1 LINEAR RANGE AND QUENCHING	12
4.2 TEMPERATURE CONSIDERATIONS.....	12
5.0 CARE AND MAINTENANCE	13
5.1 RINSING.....	13
5.2 CLEANING THE OPTICS	13
6.0 WARRANTY	14
6.1 TERMS	14
6.2 WARRANTY SERVICE	14
6.3 OUT-OF-WARRANTY SERVICE.....	14
APPENDIX A	16
CYCLOPS-7 SPECIFICATIONS	16
APPENDIX B	17
CYCLOPS-7 WIRING TABLE.....	17
GAIN SWITCHING TABLE.....	17
APPENDIX C	18
CYCLOPS-7 PIGTAIL CABLE AND CONNECTOR INFORMATION.....	18
APPENDIX D	19
REQUEST FOR QUOTE TEMPLATE FOR NON-STANDARD PIGTAIL CABLE LENGTH/CONNECTOR FOR USE WITH CYCLOPS-7	19
APPENDIX E	20
CONTROLLING THE GAIN OF CYCLOPS-7.....	20

METHOD 1 - STATIC GAIN CONTROL.....	20
METHOD 2 - DYNAMIC GAIN CONTROL	20
<i>Output type 1: Digital Signals</i>	20
<i>Output type 2: Open Collector Signals</i>	20
<i>Output type 3: Relays</i>	20
APPENDIX F	21
DATABANK OPTION	21
DATABANK USES FOR DIFFERENT SAMPLING PROTOCOLS	21
CONNECTING THE CYCLOPS-7 TO TURNER DESIGNS' DATABANK.....	21



**Equipment Specified as Electrical and Electronic Waste
Smaltimento di apparecchiature elettriche ed elettroniche da rottamare**

1.0 Introduction

1.1 Description

The Turner Designs' CYCLOPS-7 Submersible Fluorometer/Turbidimeter is an accurate single channel detector that can be used for many different applications. It is intended for integration into multi-parameter systems from which it will receive power and deliver a voltage output that is proportional to the concentration of the fluorophore, particle, or compound of interest.

The CYCLOPS-7's voltage output can be correlated to concentration values by calibrating with a standard of known concentration.

1.2 Inspection and Setup

The CYCLOPS-7 shipment package consists of:

- CYCLOPS-7 Analog Detector (P/N: 2100-000) configured and factory scaled for the specified analysis (see identification letter stamped on the connector for specified analysis):
 - “C” = Chlorophyll
 - “R” = Rhodamine
 - “F” = Fluorescein
 - “P” = Phycocyanin
 - “E” = Phycoerythrin
 - “U” = CDOM
 - “O” = Crude Oil
 - “B” = Optical Brighteners
 - “T” = Turbidity
 - “G” = Refined Fuels

- CYCLOPS-7 Documentation Kit includes CD (P/N: 990-2100) with:
 - User's Manual
 - Quick Start Guide
 - Flow Cap assembly instructions
 - Shade Cap assembly instructions
 - *in vivo* Calibration Procedure
 - Secondary Standard Instructions

- Calibration Certificate

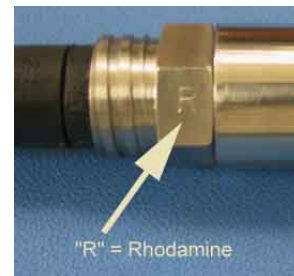

Optional Accessories include:

- Cyclops-7 analog pigtail cables (*see Appendix D for more information*)
- Solid Standard, P/N: 2100-900
- DataBank handheld data logger (*see Appendix F*)
- Cyclops-7 sensors can also be configured with Titanium Housing, which withstands corrosion better than stainless steel and is recommended for highly corrosive environments. Please contact Turner Designs for this option.

1.3 Functional Test

To perform a functional check on the CYCLOPS-7, connect the interface colored wires to the power supply and multi-meter as shown in Figure 1 below.

Additional Equipment required for functional tests:
DC Power Supply, 3 - 15 VDC, >100 mA
Multi-meter to read 0 – 5 VDC



Note: Supply voltages greater than 15 VDC will result in damage to the sensor.

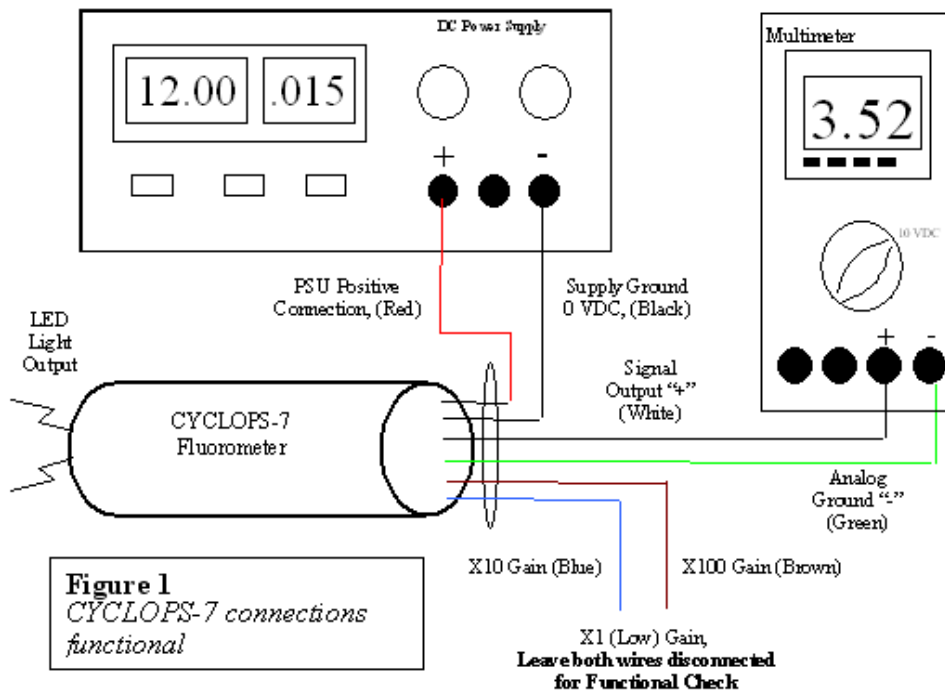

With the CYCLOPS-7 connected as shown in Figure 1 answer questions 1-3 by making the following functional tests:

1. Is the LED on?
Hold a piece of white paper about ½ an inch in-front of the optical head to ensure the LED is on (**Note: cannot perform this test for Turbidity sensors because they use IR which is not visible**)
2. Is there voltage output?
The multi-meter should be reading some voltage >0 VDC
3. Does the voltage output change?
Move the light source close to your hand or a surface and ensure the voltage output increases

2.0 Measurements with the Cyclops-7

Introduction

The following information will describe how to:

- Determine and set the appropriate gain
- Calibrate the Cyclops-7 using standards with known concentrations
- Make measurements with the CYCLOPS-7
- Use the Solid Secondary Standard

(Note: to make accurate and repeatable measurements it is important to keep the sensor clean; see page 12 for information on cleaning your sensor)

2.1 Setting the Gain

Gain setting refers to the sensitivity configuration of the sensor. There are three gain settings; X1, X10 and X100. As the gain increases, the sensitivity increases and the concentration range decreases.

2.1.1 Gain Determination Procedure

- 1) For *in vivo* applications, take a natural sample of water from a sampling station where you plan to deploy the CYCLOPS-7. Applying good measurement practices, store it properly, and quickly transport it to a laboratory where you have the CYCLOPS-7 connected to a multi meter and DC power source (see *Figure 1*).
- 2) Pour the water sample into to a clean glass beaker and submerge the optical end of the CYCLOPS-7 (See the section on “Recommended Measurement Practices for using your CYCLOPS-7 in the Lab” for how best to accomplish these steps).
- 3) Activate the X10 gain setting (see *Wiring Table on page 16*) if you believe the sample to represent a typical condition. You would like to obtain a signal from the sample that is significantly higher than a blank sample, (de-ionized water or filtered seawater), but not a signal that is close to the maximum of 5 Volts.
- 4) If the sample signal is high, (>3.0 V for example) you may choose to use the X1 gain instead of the X10 gain setting so that you avoid going over scale once you deploy the CYCLOPS-7.
- 5) If the sample signal is very low (<0.3V) you may choose to use the X100 gain setting to achieve higher sensitivity but a smaller measurable range

This process is easier for dye tracing applications. Simply create the dye dilution of interest and record what signal level it provides on the three gain settings. Once the appropriate gain setting has been determined, order an integration cable for that particular gain (See *Appendix D for more information on integration cables*).

2.1.2 Static Gain Control

If integrating into a multi parameter system or data logger that is setup for “Static Gain Control”, which refers to the use of only one gain setting at a time, then you must determine which gain to use prior to deployment and have an integration cable made to activate that specific gain (see *Appendix B*). For most applications the x10 gain will provide the best sensitivity, range, and resolution.

If you are uncertain of which gain setting to use you can take readings of a representative sample of water in the laboratory and determine which gain is the most appropriate. Customers wanting to dynamically change the gain ranges to achieve the optimum operating range should refer to “Method 2 – Dynamic Gain Control” in Appendix E on how to interface with a Data Collection System with programmable outputs.

2.1.3 Auto Gaining

Certain data loggers or multi parameter systems will have an auto gaining feature which will automatically adjust the sensitivity according to the voltage output from the CYCLOPS-7 sensor. This feature maximizes the performance of CYCLOPS-7 sensors allowing users to detect a broad range of concentrations, obtain the best resolution, and read minimum detection limits without having to rewire or manually change the sensor’s sensitivity. Turner Designs currently manufactures the DataBank handheld data logger (*see Appendix F*), which is a data logger that can be used with CYCLOPS-7 sensors and has the auto gain feature and other functions that help maximize the performance of CYCLOPS-7 sensors.

2.2 Calibration Using Standard(s) with known Concentrations

Calibrating the Cyclops-7 is a simple process, which requires the use of calibration standards. The Cyclops-7 can be calibrated using a single calibration standard, which correlates the standard’s concentration to the voltage measured for that specific standard:

- 1) Connect the Cyclops-7 to a power source and set the Cyclops-7 to a gain setting (*see section 2.1.1 for explanation on how to determine gain*)
- 2) Measure the voltage from a blank sample for the configured gain setting. (**Note: a good blank to use for this application is ultra pure or de-ionized water**)
- 3) Use a standard of known concentration and create a correlation between the standard’s concentration and its voltage output
- 4) Once a correlation has been made, use the following equation to calculate concentration values for sample measurements for the calibrated gain:

$$C_{\text{Sample}} = [(C_{\text{Std}}) / (\text{Volts}_{\text{Std}} - \text{Volts}_{\text{Blank}})] * (\text{Volts}_{\text{Sample}} - \text{Volts}_{\text{Blank}})$$

C_{Std} = Concentration value of standard used for calibration

C_{sample} = Concentration of sample

$\text{Volts}_{\text{Std}}$ = voltage reading from standard concentration

$\text{Volts}_{\text{Sample}}$ = voltage reading from sample(s)

$\text{Volts}_{\text{Blank}}$ = voltage reading from blank

2.3 Recommended Lab Practices for Cyclops-7 Measurements

The following steps will improve the accuracy and repeatability of your measurements, especially at low concentration levels:

1. Use a Glass Beaker for your water samples. (**Note: Avoid plastic beakers – plastic fluoresces and will interfere with the sample fluorescence**)
2. Place the glass beaker on a Non-Reflective Surface, preferably black.

3. Ensure that the sensor is more than 3 inches above the bottom of the glass beaker.
4. Ensure that the sensor is in the center of the glass beaker, and has more than 2 inches clearance between the circumference of the sensor and the inside surface of the beaker. Turner Designs recommends using a 1L Glass Beaker for measurements with CYCLOPS-7 units.

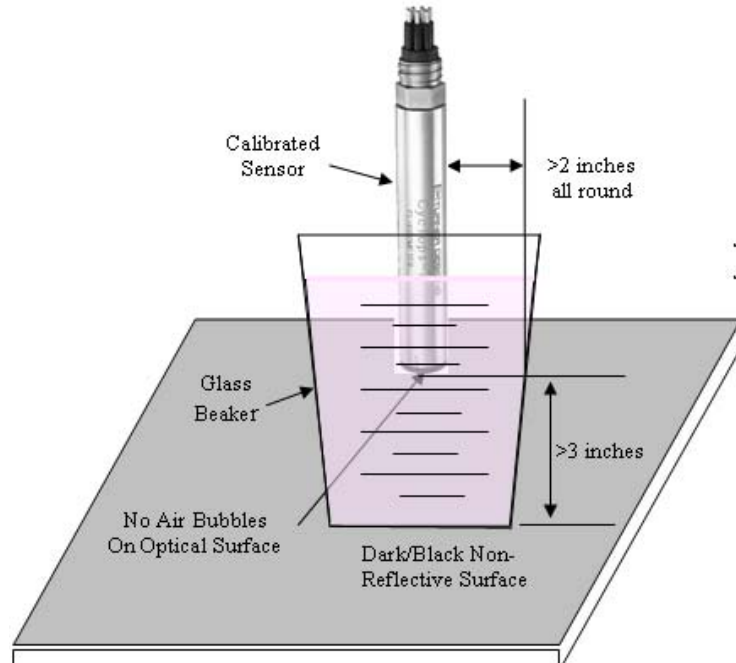

Figure 2
Summary of good measurement practices for using a submersible fluorometer in the lab.

5. Check that the optical surface of the sensor is free of air bubbles.
6. Be sure your sensor is calibrated, (see page 9 for Calibration Procedure).
7. To maximize consistency between measurements, place sensor at exactly the same height for each sample. This is most easily done using a Lab Stand.

2. 4 Using the (SSS) Solid Secondary Standard, (Optional Accessory)

The following information describes how to use the (SSS) Solid Secondary Standard, (P/N: 2100-900), with CYCLOPS-7 sensors (**Note: The Turbidity or UV Cyclops units do not have a solid secondary standard**).

The two main benefits of using the SSS are:

- 1) It can be used in place of a primary liquid standard once a correlation between a primary standard and the SSS has been established.
- 2) It can be used to check the stability of the instrument, and/or check for loss in sensitivity resulting from the growth of bio-fouling organisms on the sensor optics.

The SSS provides a very stable fluorescent signal. It has an adjustment screw so that you can tune the SSS to provide a signal to match a specific sample.

2. 4.1 Installing the Solid Secondary Standard

1. Before installing the SSS you must ensure that the optical surface of the CYCLOPS-7 is completely clean and dry. The SSS is indexed and it must be installed so that the indexing is precisely aligned for proper use (see Figure 3).

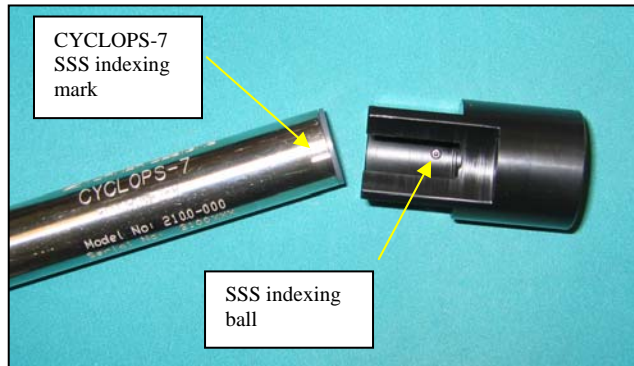

Figure 3.
Align the index mark and indexing ball when installing CYCLOPS-7 in the SSS.

2. To install, place the SSS on to the optical end of the CYCLOPS-7.
3. With the SSS fully pressed on, rotate in either direction until you feel the SSS indexing ball click into the indexing mark on the CYCLOPS-7.
4. Use a flat-head screwdriver to unscrew the locking nut as far as it will go.

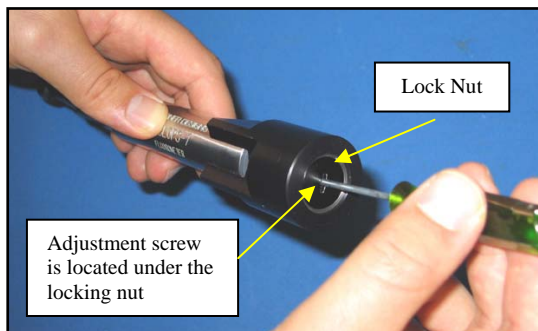

Figure 4
Insert the supplied green screwdriver through the calibration hole in the locking nut to reach the adjustment screw.

5. To change the signal level using the green screwdriver provided, insert the blade through the hole in the locking nut. Rotate it until it engages with the adjustment screw that is beneath the locking nut. Now the screw can be used to adjust the signal level as necessary.
6. Once the desired reading has been obtained, the locking nut should be screwed down so that the adjustment screw is held firmly in place.
7. Finish by noting the output voltage and gain setting used, (X1, X10 or X100) in the "Value" space on the SSS label
8. Note that the response of every solid standard is unique. Hence, a new correlation must be determined for every sensor. For future identification, use the "ID" space on the label as a unique identifier for the SSS.

2. 4.2 Using the Solid Secondary Standard for *In Vivo* Chlorophyll Application

1. To establish a correlation between a known chlorophyll concentration and the fluorescence output voltage immerse the sensor in a sample containing algae and note the sensor output voltage and gain setting used, (x1, x10 or x100).
2. Dry off the CYCLOPS-7, attach the SSS, using the same gain setting adjust the SSS to produce the same output voltage from the sensor as in step 1 (*turning the SSS adjustment screw clockwise produces a lower signal*).
3. Next, perform a chlorophyll extraction using a Laboratory Fluorometer, Spectrophotometer, or HPLC to determine the actual chlorophyll a concentration in the sample. This will provide the correlation of actual chlorophyll a concentration for the sensor output voltage at that given gain setting.
4. Now, at any time, the SSS can be used to check/establish a correlation between a known equivalent concentration and the output voltage of the current CYCLOPS-7 (**Note: CYCLOPS-7 must be on the same gain setting as in Step 1**).

2. 4.3 Using the Solid Secondary Standard for Dye Tracing Application

The SSS accessory can also be used to check the fluorescence stability for making dye concentration measurements. If necessary, the SSS can be used to establish a new correlation to voltage output without the need to use a calibration solution each time.

1. To establish a correlation between a known dye concentration and the voltage output (fluorescence) using the SSS, immerse the sensor in a dye solution of known concentration and note the sensor's voltage output and gain setting used.
2. Dry off the optical end of the CYCLOPS-7, attach the SSS, and adjust to produce the same voltage output from the sensor as in step 1 (*turning the SSS adjustment screw clockwise produces a lower output*).
3. Now, at any time, the SSS can be used to check/establish a correlation between a known equivalent concentration and the voltage output of the current CYCLOPS-7.
4. Comprehensive information on dye trace measurements can be found at the following Turner Designs URL:

(Note: Solid Secondary Standards are NOT available for Turbidity or UV Cyclops sensors)

3.0 Turbidity Cyclops-7

Introduction

The Turbidity Cyclops-7 measures turbidity using an 850nm light source and detection of scattered light at a 90-degree angle, which is similar to many modern day bench top turbidity meters. This unit provides a quick and accurate way to determine *in situ* turbidity, eliminating the collection and storage of samples and minimizing the potential error associated with sample handling and processing.

3.1 Calibration

Calibrating the Turbidity Cyclops-7 is a simple process, which requires the use of calibration standards. Turner Designs recommends purchasing [Amco Clear Analytical Turbidity Standards](#) for non-ratio instruments because these standards are non-toxic safe solutions consisting mainly of de-ionized water that comes prepared in a broad range of concentrations and has a shelf life guaranteed for one year. The Turbidity Cyclops-7 can be calibrated using a single calibration standard, which correlates the concentration to the voltage measured for that specific standard:

- 1) Connect the Turbidity Cyclops-7 to a power source and set the Turbidity Cyclops-7 to a gain setting (see "Setting the Gain" section 2.1 for explanation on how to set the gain)
- 2) Measure the voltage from a blank sample for the configured gain setting. (**Note: a good blank to use for this application is ultra pure or de-ionized water**)
- 3) Use a turbidity standard of known concentration (NTU) and create a correlation between the standard (NTU) and its voltage output
- 4) Once a correlation has been made, use the following equation to calculate turbidity values for sample measurements for the calibrated gain:

$$NTU_{\text{Sample}} = [(NTU_{\text{Std}}) / (\text{Volts}_{\text{Std}} - \text{Volts}_{\text{Blank}})] * (\text{Volts}_{\text{Sample}} - \text{Volts}_{\text{Blank}})$$

NTU_{Std} = Concentration value of standard used for calibration

NTU_{Sample} = Concentration of sample

$\text{Volts}_{\text{Std}}$ = voltage reading from standard concentration

$\text{Volts}_{\text{Sample}}$ = voltage reading from sample(s)

$\text{Volts}_{\text{Blank}}$ = voltage reading from blank

4.0 Recommended Measurement Practices

4.1 Linear Range and Quenching

The linear range is the concentration range in which the CYCLOPS-7 output is directly proportional to the concentration of the signal. The linear range begins with the smallest detectable concentration and spans to an upper limit (concentration) that is dependent upon the properties of the material, filters used, and path length.

A non-linear relationship is seen at very high concentrations where the signal does not increase at a constant rate in comparison to the change in concentration (see *Figure 5 below*). At even higher concentrations, the signal will decrease even though the sample concentrations are continuing to increase. This effect is known as “signal quenching”. Linearity can be checked by diluting a sample 1:1 or some other convenient ratio. If the sample is still in the linear range, the reading will decrease in direct proportion to the dilution. If the reading does not decrease in direct proportion to the dilution, or if the reading increases, the sample is beyond the linear range.

4.2 Temperature Considerations

Fluorescence is temperature sensitive. As the temperature of the sample increases, the fluorescence decreases. For greatest accuracy, record the sample temperature and correct the sensor output for changes in temperature.

For further information on how temperature, light, water quality and the physiological state of the algal cells can all affect the measurement of chlorophyll *a*, please refer to the application

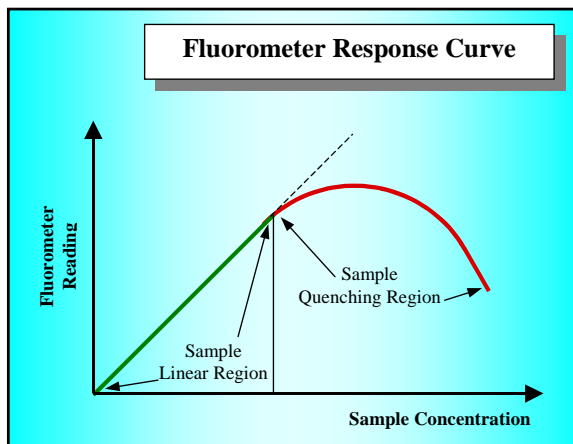

Figure 5
Graph showing Linear and Quenching Regions of the sample's response

section of Turner Designs' web site at the following URL:

<http://www.turnerdesigns.com/esupport/understanding.html>

5.0 Care and Maintenance

5.1 Rinsing

The CYCLOPS-7 should be rinsed or soaked in freshwater following each deployment, ideally until it is completely clean again.

5.2 Cleaning the Optics

The optical window should be visually inspected after each deployment following a soaking in fresh water. If cleaning is needed, use optical tissue to clean the window with soapy water.



Note: The CYCLOPS-7 should not come in contact with any organic solvents (i.e. acetone, methanol) or strong acids and bases.

The UV Cyclops-7 models are the **ONLY** Cyclops-7 sensors that can be calibrated with Quinine Sulfate standards made in Hydrosulfuric Acid. All other Cyclops-7 models **CANNOT** be used in **Hydrosulfuric Acid**.

6.0 Warranty

6.1 Terms

Turner Designs warrants the CYCLOPS-7 and accessories to be free from defects in materials and workmanship under normal use and service for a period of 12 months from the date of shipment from Turner Designs with the following restrictions:

- Turner Designs is not responsible for replacing parts damaged by accident or neglect. Your instrument must be installed according to instructions in the User's Manual. Damage from corrosion is not covered. Damage caused by customer modification of the instrument is not covered.
- This warranty covers only Turner Designs products and is not extended to equipment used with our products. We are not responsible for accidental or consequential damages, except in those states where this limitation is not allowed. This warranty gives you specific legal rights and you may have other rights which vary from state to state.
- Damage incurred in shipping is not covered.

6.2 Warranty Service

To obtain service during the warranty period, the owner shall take the following steps:

1. Write, email, or call the Turner Designs Technical Support department and describe as precisely as possible the nature of the problem.

Phone: 1 (877) 316-8049

Email: support@turnerdesigns.com

2. Carry out any adjustments or tests as suggested by the Technical Support Department.

3. If proper performance is not obtained you will be issued a Return Authorization number (RMA). Package the unit, write the RMA number on the outside of the shipping carton, and ship the instrument, prepaid, to Turner Designs. If the failure is covered under the warranty terms, the instrument will be repaired and returned free of charge, for all customers in the contiguous continental United States.

For customers outside of the contiguous continental United States who purchased equipment from one of our authorized distributors, contact the distributor. If you have purchased directly, contact us. We will repair the instrument at no charge. Customer pays for shipping duties and documentation to Turner Designs. Turner Designs pays for return shipment (custom duties, taxes and fees are the responsibility of the customer).

6.3 Out-of-Warranty Service

Follow steps for Warranty Service as listed above. If our Technical Support department can assist you by phone or correspondence, we will be glad to, at no charge. Repair service will be billed on a fixed price basis, plus any applicable duties and/or taxes. Shipment to Turner Designs should be prepaid. Your bill will include return shipment freight charges.

Address for Shipment:
Turner Designs, Inc.
845 W. Maude Ave.
Sunnyvale, CA 94085



Equipment Specified as Electrical and Electronic Waste
Smaltimento di apparecchiature elettriche ed elettroniche da rottamare

Appendix A

CYCLOPS-7 Specifications

Parameter	Specification
Minimum Detection Limit	0.025 µg/L Chlorophyll <i>a</i> 0.01 ppb Rhodamine WT & Fluorescein 150 cells/mL Cyanobacteria (PE & PC) 0.05 NTU Turbidity 0.4 ppb QS** CDOM 0.2 ppb QS** Crude Oil in water 1 ppb QS** Optical Brighteners 2 ppb NS*** Refined Fuels **Quinine Sulfate ***Naphthalene disulfonic disodium salt
Linearity (full range)	0.99 R ²
Power Draw	@3V: Max 360 mW ≥5V: Max 265 mW
Input Voltage	3 – 15 VDC
Signal Output	0 – 5 VDC
Temperature Range	Ambient: 0 to 50 °C Water Temp: -2 to +50 °C
Light Source	Light Emitting Diode
Excitation Wavelength	Visible – (Chl, RWT, PC, PE, F) UV – CDOM, Oil, OB, RF IR – Turbidity
Detector	Photodiode
Detection Wavelength	300 – 1100 nm
Warm up time	5 seconds
Dimensions, (length excludes connector)	Length: 4.3", 10.9cm Diameter: 0.875", 2.22cm
Weight	5.0 ounces, 160 gm
Depth Rating	600 meters
Housing Material	(Standard) 316 Stainless Steel (Optional) Titanium

Appendix B

CYCLOPS-7 Wiring Table

CYCLOPS-7 Wire	Pin Number	Function	Connection
Red	1	Supply Voltage 3 – 15 VDC	PSU – Positive Connection
Black	2	Supply Ground, 0VDC	PSU – Ground Connection
White	3	Signal Out to data logger, “+”, 0 – 5VDC	Multimeter Positive Connection
Green	4	Analog Ground “-”, 0 VDC	Multimeter Negative Connection
Blue	5	X10 Gain, (Medium Sensitivity)	See table below
Brown	6	X100 Gain, (High Sensitivity)	See table below

Gain Switching Table

Gain 10 (Blue)	Gain 100 (Brown)	Gain	Chl Range (µg/L)	RWT Range (ppb)	TRB Range (NTU)
Not connected	Not connected	X 1	0 - 500	0 – 1,000	0-3000
Connected to analog ground	Not connected	X 10	0 – 50	0 - 100	0-1000
Not connected	Connected to analog ground	X 100	0 – 5	0 - 10	0-100

Appendix C

CYCLOPS-7 Pigtail Cable and Connector Information

Figure 7

Dimension details of 24" length cable with 20 gauge colored lead wire, connects to 6 pin male connector. (Cable manufacturer/Part No: IMPULSE/MCIL-6-FS)

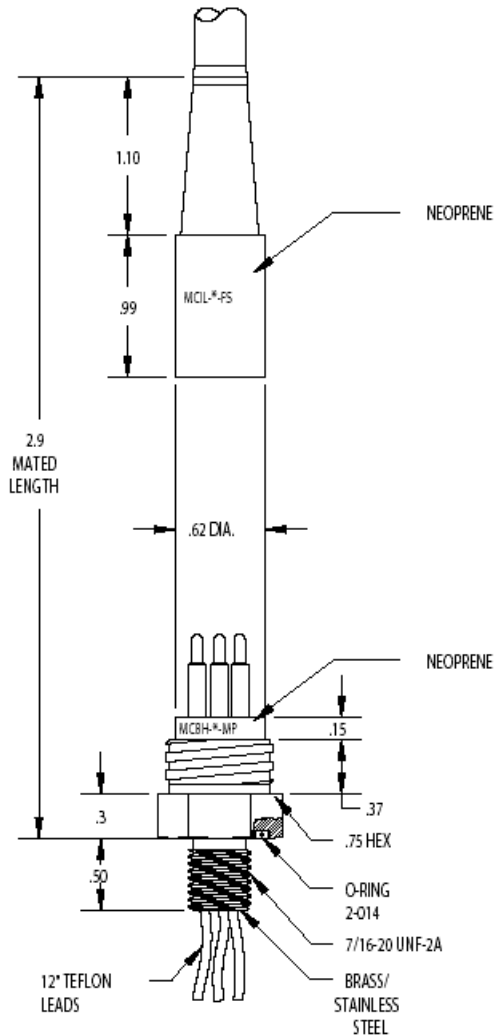

Figure 8

Female locking sleeve,
(Impulse P/No. MCDLS-F)

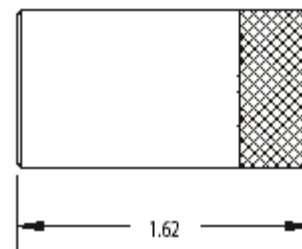

Figure 9

In-line connector contact
configuration (connects
to CYCLOPS-7).



See Appendix D for a Quote Request template to order a non-standard pigtail cable length/connector for use with the CYCLOPS-7 Fluorometer

A Maximum cable length up to 300 meters can be connected to the CYCLOPS if the following conditions are met.

- 1) The cable is shielded and contains 20 gauge conductor size or greater (i.e. Belden No. 8426 cable).
- 2) The 0-5 volt Analog output is connected to a device (i.e. Data Logger) with an input impedance of 1 MegOhm or greater.
- 3) The supply Voltage to the CYCLOPS is between 5 and 15 volts.

Appendix D

Request for Quote Template for Non-Standard Pigtail Cable Length/Connector for Use with CYCLOPS-7

Turner Designs offers the following lengths for Cyclops-7 analog pigtail cables with locking sleeves:

- 2 foot (P/N: 2100-750)
- 5 meter (P/N: 2100-755)
- 10 meter (P/N: 2100-751)
- 25 meter (P/N: 2100-752)
- 50 meter (P/N: 2100-753)

To request a quote from Impulse Enterprise for a custom pigtail cable/connector, follow these steps:

1. Complete the 6 lines below between the asterisks (*) with your specific information.
2. Highlight the lines between the asterisks (*) and copy to the PC clipboard.
3. Paste the information into the "Comments" field on the Contact Us page on the Impulse Enterprise web page at the following URL:
<http://www.impulse-ent.com/inquiry.html>
4. Complete the remaining fields of the Impulse Enterprise <Contact Us> e-mail form
5. Click on "Send E-Mail".

Please quote for a custom pigtail cable/connector for use with Turner Designs CYCLOPS-7 fluorometer to meet the following requirements:

1. Pigtail is required for integration with _____
(Identify multi-parameter system as appropriate)
2. Cable Length (to include connectors) _____, (see Page 15 for max length)
(State units, feet, meters, etc.)
3. Configured for ____X1, ____X10, ____X100 gain range on CYCLOPS-7
(Put a checkmark against desired gain)
4. Required connector on non-CYCLOPS end of pigtail: _____
(Provide sufficient information for Impulse Enterprise to request a quote for the required "host" end of cable)
5. Pin out from Host End to CYCLOPS end: _____ or advise:
 - a. Supply Voltage (+) from Host is carried on pin _____
 - b. Supply Ground from Host is carried on pin _____
 - c. Analog Signal to Host is carried on pin _____
 - d. Analog Ground to Host is carried on pin _____Provide sufficient information for Impulse Enterprise to make the proper electrical hook-up between the two connector ends)
6. No. of Pigtails required _____

(Provide contact details if different from your information entered in the Impulse Enterprises fields on their "Contact Us" e-mail form.)

.....

For assistance from Turner Designs, call 1 877 316-8049
For assistance from Impulse Enterprise, call 1 800 327-097

Appendix E

Controlling the Gain of CYCLOPS-7

The operating range can either be set to one of the 3 available ranges, which will be referred to as "Static Gain Control", or it can be dynamically changed to achieve the optimum operating range, referred to below as "Dynamic Gain Control". The first approach is applicable to using the CYCLOPS-7 as a stand-alone sensor. The second approach is applicable to when the CYCLOPS-7 is integrated into a system with control capability. Both methods are implemented by grounding "driving Low" the appropriate gain control pin. The X10 and X100 gain control pins are normally in a "High" state if they are not connected to anything. This means the CYCLOPS-7 default is the X1 gain (largest concentration range) mode. The CYCLOPS-7 can be put into higher gain, lower concentration range modes, by connecting either the X10 or X100 pin (**but not both at the same time**) to ground.

Method 1 - Static Gain Control

Connect the X10 or X100 pin to the analog ground pin of the CYCLOPS-7 pigtail connector. See the Gain Switching Table in Appendix B to determine the required configuration for desired gain/measurement range. See Appendix C for Pigtail Cable and Connector information. Also, see "Setting the Gain" section 2.1 for more information on "Static Gain Control".

Method 2 - Dynamic Gain Control

If you have a Data Collection System (DCS) that has programmable outputs you can use them to control the CYCLOPS-7 gain settings. Following are three common output types found in DCSs and how to connect them to the CYCLOPS-7. Refer to your DCS manual to determine which is appropriate. For those who want technical data: the CYCLOPS-7's X10 and X100 gain control pins are connected internally to the input of a Schmitt trigger inverter, part number 74LVC1G14, and a 100K ohm pull-up resistor. Both use a 5-Volt power supply.

Output type 1: Digital Signals

Logic signals can be used to drive the gain control pins. In most cases you can connect the digital signal output of the DCS directly to the CYCLOPS-7 gain control pins. To drive them high, the voltage should be 3 VDC min – 5 VDC max. To drive them low, the voltage should be 1 VDC max – 0 VDC min. You may need to connect the CYCLOPS-7 analog ground to the DCS ground.

Output type 2: Open Collector Signals

This type of output is either open or connected to ground. Connect the CYCLOPS-7 gain control pins directly to these outputs. You may need to connect the CYCLOPS-7 analog ground to the DCS ground.

Output type 3: Relays

Relays act as a controllable switch. Connect one end of the relay to the CYCLOPS-7 analog ground. Connect the other end of the relay to the CYCLOPS-7 gain control pin.

Appendix F

DataBank Option

Cyclops-7 sensors are analog output devices that produce a 0 – 5 volt signal that is proportional to the fluorophore being measured. Turner Designs offers the DataBank, a universal handheld meter, datalogger, and power supply that can be used to maximize performance of Cyclops-7 sensors with functions such as:

- Auto gaining
- User defined calibrations
- Large internal memory
- Interval logging

The DataBank comes with intuitive GUI software that allows users to easily calibrate, set up logging, download data, and define parameters and values necessary to help configure the Cyclops-7 for a specific application or study. Available options include **GPS capability**, **external power**, **travel case**, and **car charger**.



DataBank uses for different sampling protocols

Monitoring – deploy the Cyclops-7 to a fixed location or depth and monitor the signal over time; set up logging to capture a signal within a specific time frame; download data while the sensor is deployed and continuously measuring; set up digital data output via HyperTerminal.

Multiple Site Measurements – measure fluorescence at different locations within your water system or across many systems; GPS enabled units provide latitude/longitude data per location;

Profiling – purchase extended cables to allow for vertical profiling;

For any application or sampling protocol, the DataBank facilitates and maximizes performance of all Cyclops-7 sensors allowing versatility and flexibility in calibration, setup, and measurement.

Connecting the Cyclops-7 to Turner Designs' DataBank

Simply connect the bare wires from the Cyclops-7's pigtail to the DataBank board as shown below and move the switch to select **dV**.

